



**Model UC-15I
Undercounter Ice Machine**

Sub-Zero undercounter units simplify life at home by bringing refrigeration anywhere it's needed. In the kitchen, a high-volume ice machine is a must for entertaining. The Model UC-15I ice machine has a storage capacity of up to 25 pounds of ice.



Model UC-15IP shown with custom overlay door panel.

Features

- Can be fitted with a custom overlay or stainless steel door front panel.
- Classic stainless steel door panel with tubular, curved or pro handles available as sales accessories.
- 24" depth design for a complete integrated look.
- Solid core door with gasket and door closer.
- Models UC-15I and UC-15IO have a gravity drain, while Models UC-15IP and UC-15IPO have a built-in pump to allow greater installation flexibility.
- Automatic ice machine provides high-quality, clear ice.
- Ice storage bin capacity of up to 25 lbs.
- Automatic defrost.
- Reversible door swing.
- Front venting with removable kickplate allows unit to be serviced from the front.
- UL approved for US and Canada.

Model Options

Model Options	UC-15I	UC-15IP	UC-15IO	UC-15IPO
Drain Type	Gravity Drain	Drain Pump	Gravity Drain	Drain Pump
Outdoor Model			■	■

Interior Features

- **Ice Machine**
- LED Bin Light
- Water Filter
- Ice Scoop



Accessories

- Classic stainless steel door front panels with tubular, curved or pro handles in 15" and 18" widths.
- Classic stainless steel handles for custom panel application.
- Classic stainless steel kickplate.
- Filler strip for 18" opening.

Accessories are available through your Sub-Zero dealer. To obtain local dealer information, visit the showroom locator section of our website, subzero.com.



Classic



**Model UC-15I
Undercounter Ice Machine**

Overall Dimensions

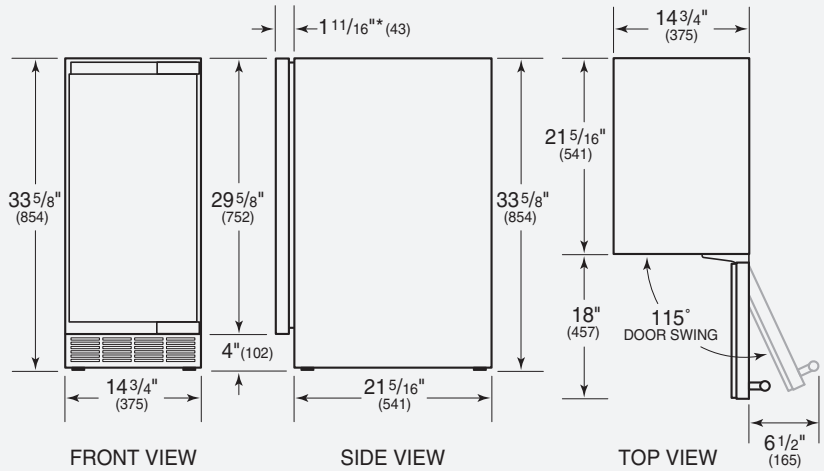

*Does not include door panel

Unit dimensions may vary by ± 1/8".

Specifications

Overall Width	14 ³ / ₄ "
Overall Height (levelers in)	33 ⁵ / ₈ "
Overall Depth	23"
Minimum Door Clearance	18"
Ice Storage Capacity	25 lbs
Opening Width	15 ¹ / ₄ "
Opening Height	34 ¹ / ₂ "
Opening Depth	24"
Minimum Height Required (levelers in)	33 ⁵ / ₈ "
Electrical Requirements	115 V AC, 60 Hz 15 amp dedicated circuit
Plumbing Requirements	1/4" copper line 20–100 psi
Shipping Weight	100 lbs

Installation Specifications

Gravity Drain Models

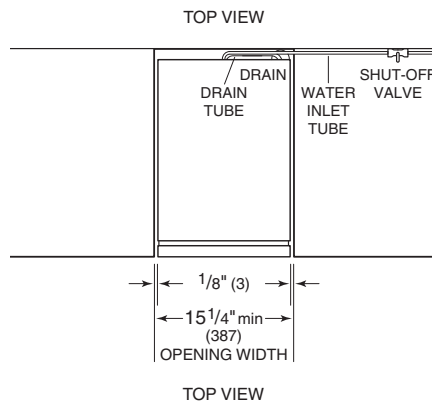

Drain Pump Models

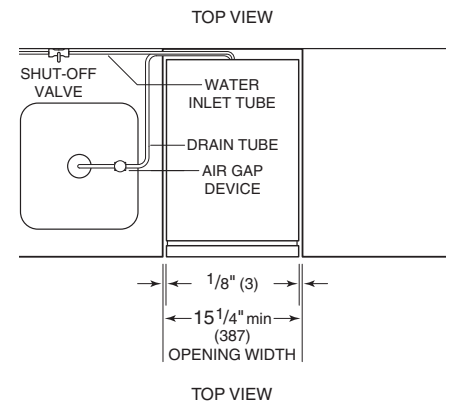

Installation Notes

The ice machine can be ordered with (Models UC-15IP and UC-15IPO) or without (Models UC-15I and UC-15IO) a drain pump. Each model has specific plumbing requirements. If you order the unit without a pump, a drain must be installed.

Complete installation specifications, including panel dimensions, can be found on our website, subzero.com.

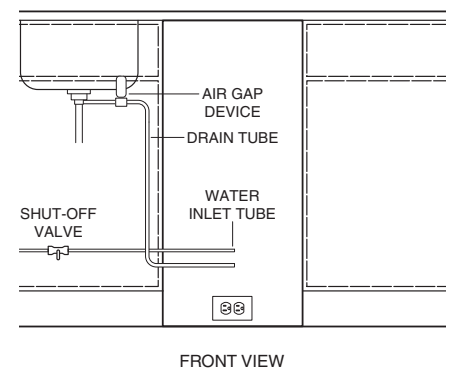
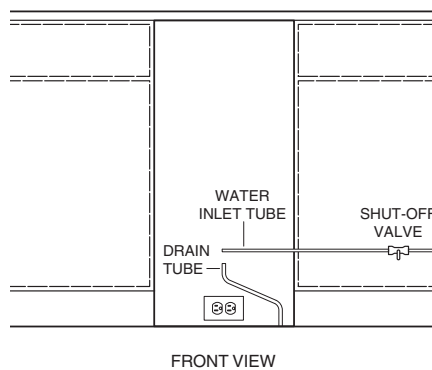

Dimensions in parentheses are in millimeters unless otherwise specified.