



48" Built-In Side-by-Side with Dispenser

Side-by-side model BI-48SD offers maximum refrigeration capacity along with an ice and water dispenser through the refrigerator door. Sub-Zero dual refrigeration along with new air purification and water filtration systems guard the freshness of your food and water like nothing before. Framed, overlay, flush inset and stainless steel design options are available. The flush inset installation allows the unit to sit flush with surrounding cabinetry.



Stainless steel model BI-48SD shown with tubular handles.

FEATURES

- Dual refrigeration system ensures the freshest food and energy efficiency.
- Electronic microprocessor constantly monitors entire unit to ensure proper food storage environment.
- Air purification system reduces odors, bacteria, viruses and ethylene gas.
- Microbiological water filtration system filters bacteria, viruses and sediment, but not fluoride.
- Dispenser provides chilled water and ice through the door.
- Illuminated touch control panel.
- Bright interior lighting throughout, including storage drawer area.
- Adjustable spill-proof glass shelves, door shelves and dairy compartment.
- Soft-close crisper and deli drawers form a lower temperature zone ideal for produce and meats.
- Easy-access flip-up grille.
- Informational freshness cards.
- Max ice feature increases production for a 24-hour period.



Flip-up grille.



Air purification system.

MODEL OPTIONS	BI-48SD/O	BI-48SD/S/TH	BI-48SD/S/PH
Design	Overlay/Framed/Flush Inset	Stainless	Stainless
Grille	Panel	Stainless	Stainless
Handle	*	Tubular	Pro

**Handle not included to allow for design flexibility.*

INTERIOR FEATURES

- **Refrigerator**
18.7 cu ft Capacity
Air Purification System
4 Adjustable Glass Shelves
1 Stationary Glass Shelf
1 High-Humidity Drawer with Divider
2 Storage Drawers with Divider
3 Adjustable Door Shelves
2 Stationary Door Shelves
Adjustable Dairy Compartment
- **Freezer**
9.6 cu ft Capacity
Water Filtration System
Automatic Ice Maker with Dispenser
2 Adjustable Wire Shelves
1 Stationary Solid Shelf
3 Storage Drawers
5 Adjustable Door Shelves

ACCESSORIES

- Grilles for 83" or 88" finished height (84" is standard).
- Framed front panels in white and stainless steel.
- Flush inset panels in stainless steel with tubular or pro handles.
- Side panel in white and stainless steel.
- Partial framed kit for stainless steel panels above and below dispenser.
- Stainless steel kickplate.
- Framed grille insert and full-length handles.
- Stainless steel tubular and pro handles.
- Dozen egg container.
- Replacement air purification cartridge and water filter.
- 90° door stop.



Accessories are available through your Sub-Zero dealer. For local dealer information, visit the find a showroom section of our website, subzero.com.



48" Built-In Side-by-Side with Dispenser

OVERALL DIMENSIONS

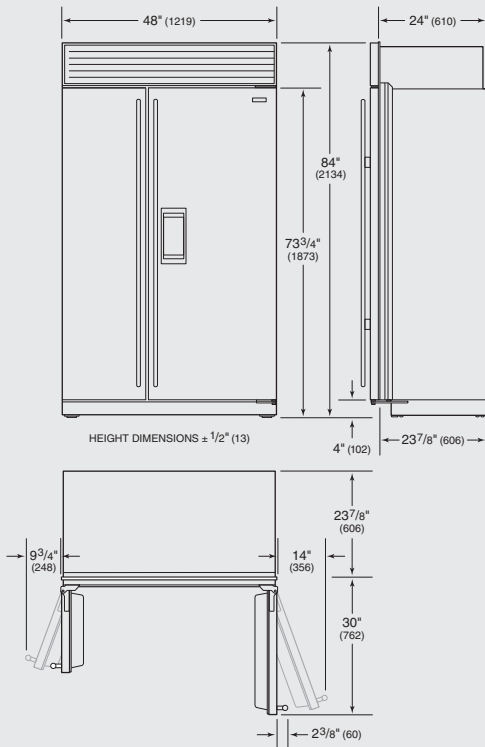

Unit dimensions may vary by $\pm 1/8"$ (3).

Dimensions in parentheses are in millimeters unless otherwise specified.

SPECIFICATIONS

Overall Dimensions	48" W x 84" H x 24" D
Door Clearance	Standard 30" Flush Inset 30 1/2"
Opening Width	47 1/2"
Flush Inset Width	50"
Opening Height	83 3/4"
Flush Inset Height	84"
Opening Depth	24"
Flush Inset Depth	26 3/16"
Electrical Requirements	115 V AC, 60 Hz 15 amp circuit
Plumbing Requirements	1/4" OD copper line 30–100 psi
Shipping Weight	656 lbs

INSTALLATION NOTES

Built-In models may be used in a standard installation or in a flush inset installation which allows the unit to be flush with surrounding cabinetry.

Complete installation specifications, including panel sizes, can be found on our website, subzero.com/specs.

INSTALLATION SPECIFICATIONS

Standard Installation

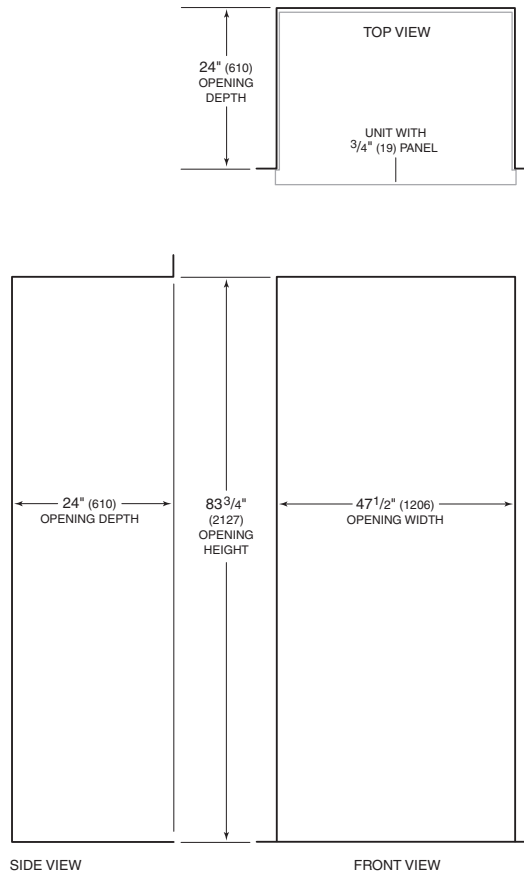

Location of Electrical Supply

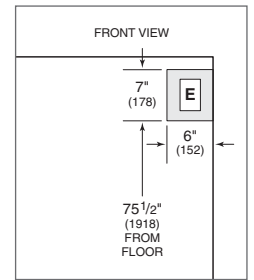

Location of Water Supply—Rear

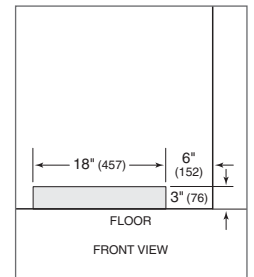

Location of Water Supply—Bottom

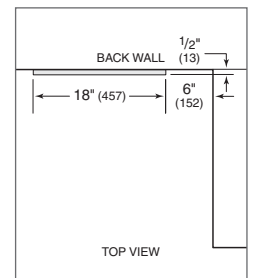

Flush Inset Installation

IMPORTANT NOTE:
Dimensions assume a 3/4" (19) panel thickness.

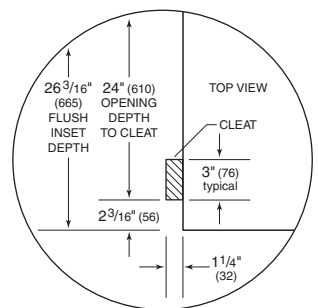
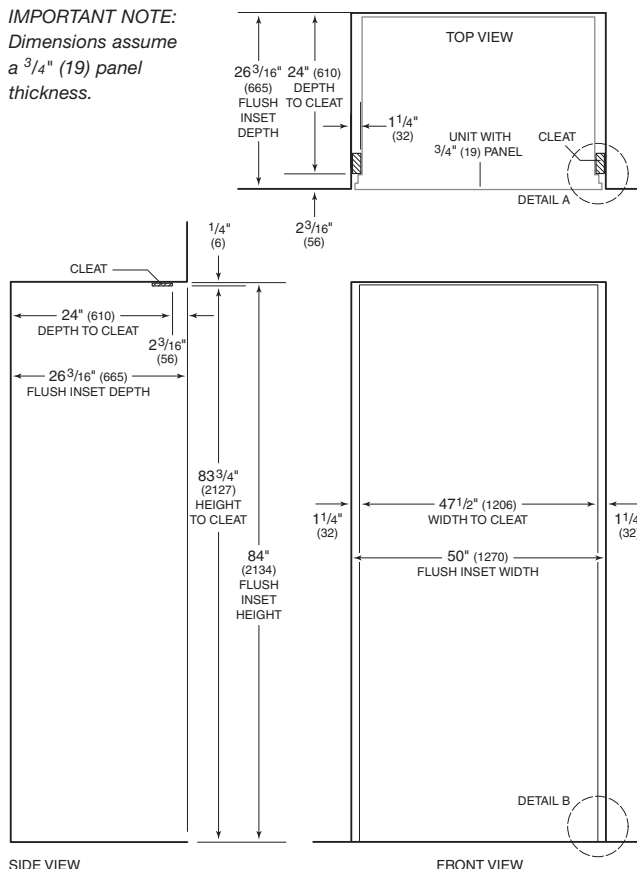

Detail A

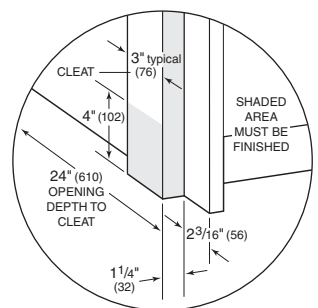

Detail B