



## 27" Integrated All Refrigerator—Tall

Integrated refrigeration can be used anywhere in the home. It merges seamlessly into the décor, with no visible hinges or grilles. Model 700TR is a 27" wide tall unit with refrigerator storage in the upper cabinet, and also in the lower drawers with a crisper cover standard in the upper drawer. Two distinct temperature zones ensure the freshest food and energy efficiency.



### FEATURES

- Custom front panels and hardware allow for infinite design options.
- Point-of-use refrigeration that can be placed anywhere in the home.
- Microprocessor maintains precise control, within 1° of set temperature in each of two temperature zones.
- Easy-access, illuminated touch control panel.
- Bright interior lighting in cabinet and drawers.
- Adjustable spill-proof glass shelves, door shelves and dairy compartment.
- Adjustable deli drawer with shelf for storage of smaller items.
- Removable crisper cover on upper storage drawer.
- Upper storage drawer is deep enough for bottled drinks to stand upright.
- Door alarm has an audible beep if door or drawer is left open.
- 90° door stop built into hinge.
- Star-K compliant with harness kit.
- Meets U.S. Department of Energy standards.

### MODEL

700TR

Design

Integrated

### INTERIOR FEATURES

- **Refrigerator**
  - Dual Refrigeration
  - 2 Temperature Zones
  - 3 Adjustable Glass Shelves
  - 1 Stationary Shelf
  - 2 Storage Drawers
  - Removable Crisper Cover
  - 2 Removable Drawer Dividers
  - Adjustable Deli Drawer
  - 3 Adjustable Door Shelves
  - Adjustable Dairy Compartment
  - Egg Container

### ACCESSORIES

- Stainless steel front panels with tubular or pro handles—80" or 84" finished height.
- Stainless steel tubular and pro handles.
- Dual installation kits for installation with column, tall or drawer model.
- Crisper drawer and shelf assembly.
- Dozen egg container.

*Accessories are available through your Sub-Zero dealer. For local dealer information, visit the find a showroom section of our website, [subzero.com](http://subzero.com).*





## 27" Integrated All Refrigerator—Tall

### OVERALL DIMENSIONS

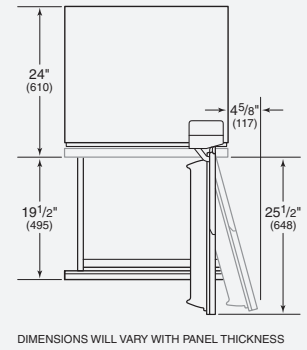
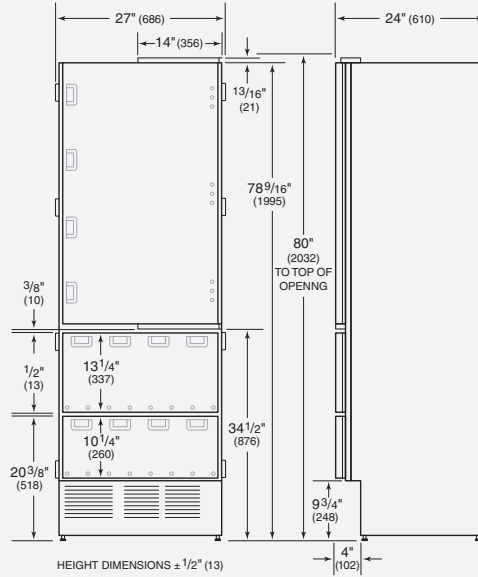

Unit dimensions may vary by ± 1/8".

### SPECIFICATIONS

Overall Width	27"
Overall Height	80"
Overall Depth	24"
Door Clearance	25 1/2"
Drawer Clearance	19 1/2"
Refrigerator Capacity	15.5 cu ft
Finished Opening	27" W x 80" H x 25" D*
Electrical Requirements	115 V AC, 60 Hz 15 amp dedicated circuit
Annual Energy Usage	\$43**
Shipping Weight	360 lbs

\*Depth is 24" from the front of the unit to its back. Your design may necessitate moving the unit back, or cabinets forward to achieve a flush fit. This will require a minimum opening depth of 25".

\*\*Based on 10.65 cents per kilowatt hour.

### INSTALLATION SPECIFICATIONS

#### Opening Dimensions

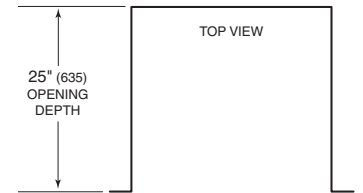
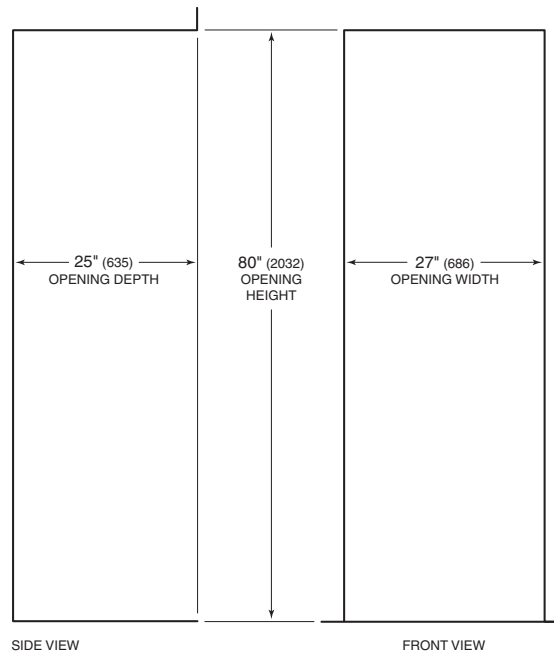

Dimensions in parentheses are in millimeters unless otherwise specified.

### INSTALLATION NOTES

Stainless steel panels with handles are available as accessories. These panels are not installed at the factory.

Complete installation specifications, including panel sizes, can be found on our website, [subzero.com/specs](http://subzero.com/specs).

#### Location of Electrical Supply

