

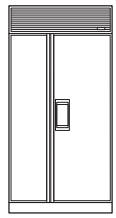

Built-In Model 685 Side-by-Side Refrigerator/Freezer with Ice and Water Dispenser

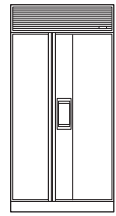

Model 685/F
Framed



Model 685/F
Partial Framed



Model 685/O
Overlay

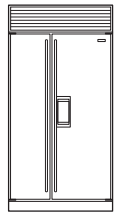

Model 685/S
Classic
Stainless Steel

Front venting allows unit to be completely built in

Serial and model number plate

Automatic ice maker

Freezer utility rack

Adjustable wire shelves

Adjustable door shelves

Roll-out freezer baskets

Four-sided magnetic gaskets

Removable kickplate

Hermetically sealed refrigeration units

Lighted electronic control panel

Adjustable dairy compartment

Adjustable spill-proof glass shelves

Bulk ice dispenser

Adjustable roll-out utility basket

Adjustable door shelves

Egg tray

High humidity crisper drawer

Door closers

(Stainless steel design shown)



With the installation of a harness kit, these appliances are Star-K compliant to meet strict religious regulations in conjunction with specific instructions found on star-k.org. You may purchase this harness kit through your Sub-Zero dealer. To obtain local dealer information, visit the Locator section of our website, subzero.com.



BUILT-IN

► The Sub-Zero Model 685 side-by-side refrigerator/freezer with ice and water dispenser is available in your choice of the framed, partial framed, overlay or stainless steel design application. The stainless steel model comes with classic stainless steel wrapped doors.

Sub-Zero offers two distinctive different models with ice and water dispensing through the door. This side-by-side unit is 42" (1067) wide and the dispenser is placed on the refrigerator door to offer a sleek look and most efficient use of interior storage space.

Dimensions in parentheses are in millimeters unless otherwise specified.



Built-In Model 685

FEATURES

- ▶ 42" (1067) wide side-by-side refrigerator/ freezer with ice and water dispenser
- ▶ Framed, overlay and classic stainless steel applications provide complete design flexibility
- ▶ If you choose not to use custom wood panels above or below the glasswell, you can order a partial framed accessory kit for your framed unit – the kit includes molding and a stainless steel panel that surrounds the glasswell and runs the total height of the refrigerator door
- ▶ With the framed retrofit accessory kit, existing Model 680 door panels can be used on a new Model 685 framed unit
- ▶ Sub-Zero's dual refrigeration system ensures the freshest food and energy efficiency
- ▶ Shallow-depth design means access is easy to any area of the refrigerator
- ▶ Electronic digital controls are up front and easy to use
- ▶ Bright interior lighting
- ▶ Adjustable, spill-proof glass shelves
- ▶ High-humidity crisper drawer is large with smooth sides for easy cleaning – there's even an added storage drawer
- ▶ Door alarm will let you know with an audible beeping if your refrigerator or freezer door is left ajar
- ▶ Automatic ice maker provides an ample supply of crescent-shaped ice – also has a bulk ice dispenser
- ▶ Solid core doors with magnetic gaskets and door closers
- ▶ Front venting allows unit to be completely built in and serviced from the front
- ▶ Meets strict Department of Energy requirements
- ▶ UL listed for US and Canada
- ▶ Two, five and twelve year residential warranty – exclusions apply, warranty information can be found on our website, subzero.com

OVERALL DIMENSIONS ▼

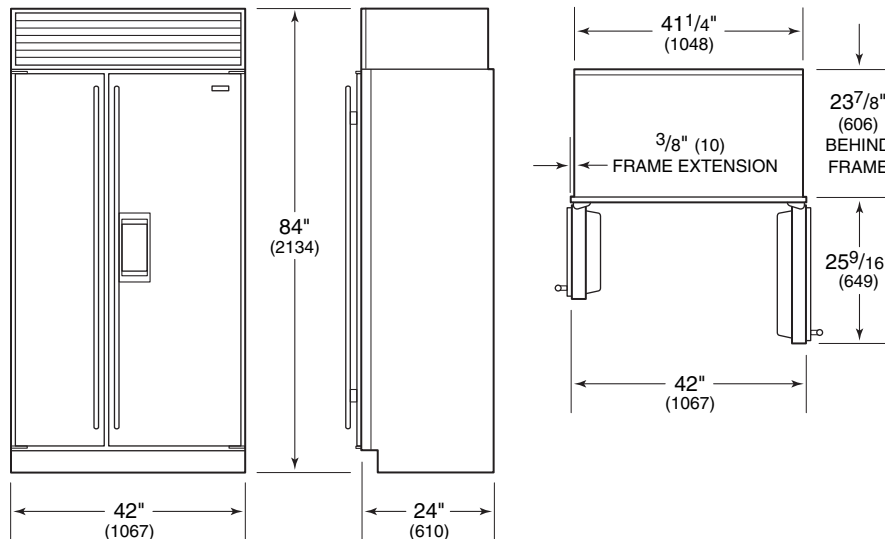

Stainless steel design shown.

Dimensions may vary by ±1/8" (3).

Dimensions in parentheses are in millimeters unless otherwise specified.



Built-In Model 685



BUILT-IN

MODEL OPTIONS ▼

Framed Design	685/F
Partial Framed Design (accessory kit required)	685/F
Overlay Design	685/O
Classic Stainless Steel	685/S

ACCESSORIES

- ▶ FRAMPAR – Partial framed kit includes molding and a stainless steel insert panel for above and below the glasswell on a framed unit
- ▶ FRAMRET – Framed retrofit kit includes moldings and stainless steel insert panels to accommodate existing Model 680 framed door panels
- ▶ Louvered, panel or stainless steel grilles in 1" (25) increments from 10" (254) to 15" (381) high
- ▶ Front and grille panels for framed design in white, almond and classic stainless steel
- ▶ Side panels in white, almond and classic stainless steel
- ▶ Stainless steel and polished chrome handles for overlay design
- ▶ Gallon door shelf
- ▶ Dozen egg container with lid
- ▶ 90° and 105° door stop kits

Accessories are available through your Sub-Zero dealer. To obtain local dealer information, visit the Locator section of our website, subzero.com.

SPECIFICATIONS ▼

Model 685	Side-by-Side Refrigerator / Freezer with Ice and Water Dispenser
Overall Width	42" (1067)
Overall Height	84" (2134)
Overall Depth	24" (610)
Refrigerator Capacity	15.6 cu ft (442 L)
Freezer Capacity	8.2 cu ft (232 L)
Minimum Height (levelers in)	83" (2108)
Door Swing Clearance	25 ⁹ / ₁₆ " (649)
Electrical Requirements	115 V AC, 60 Hz, 15 amp circuit
Plumbing Requirements	1/4" copper line
Water Supply	20–100 psi
Annual Energy Usage (based on 9.06 cents per kilowatt hour)	694 kWh / \$63
Shipping Weight	Framed – 569 lbs (258 kg) Overlay – 569 lbs (258 kg) Stainless Steel – 608 lbs (276 kg)
Special Note	Overlay design is now available for this ice and water dispensing unit

Specifications are subject to change without notice.



Built-In Model 685

INSTALLATION SPECIFICATIONS



BUILT-IN

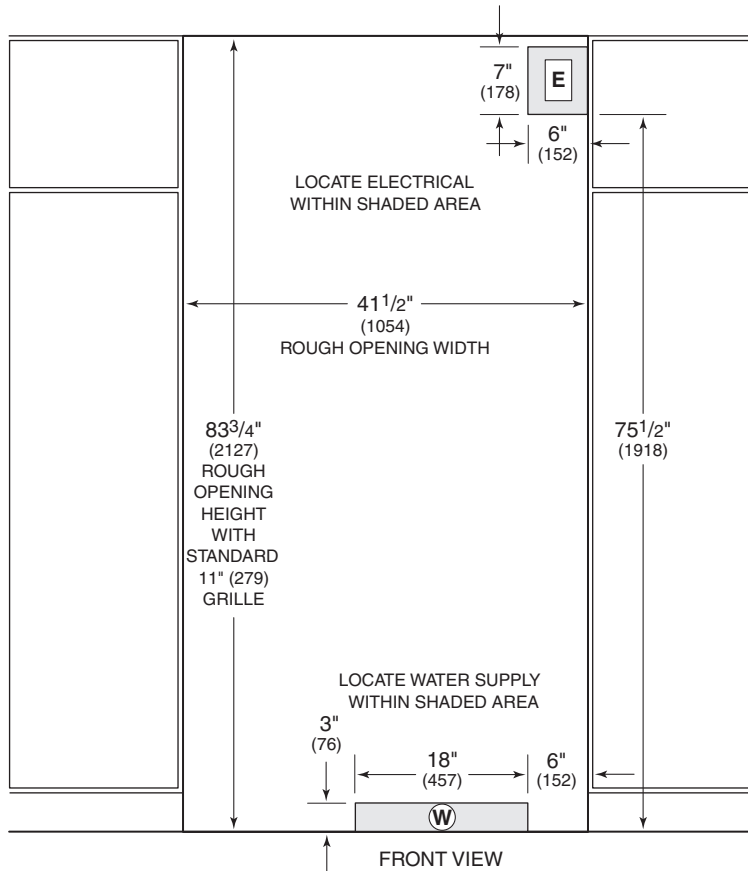
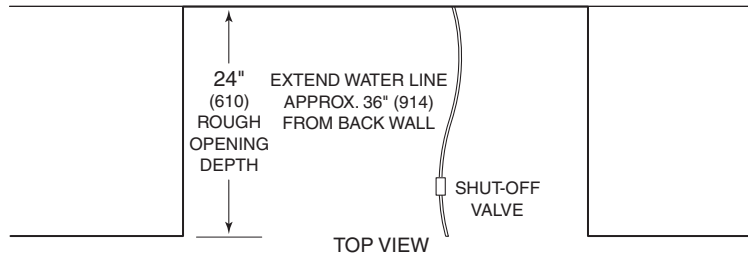

DIMENSIONS

Finished Rough Opening Width	41 1/2" (1054)
Finished Rough Opening Height	83 3/4" (2127)
Finished Rough Opening Depth	24" (610)
Location of Electrical	Within upper shaded area
Location of Water Supply	Within lower shaded area

See Installation Instructions shipped with unit for detailed specifications.
 Refer to the Sub-Zero Design Guide pdf file for additional specifications.

Dimensions in parentheses are in millimeters unless otherwise specified.



Built-In Model 685

INSTALLATION NOTES

- ▶ Refer to the illustrations and specifications for overall dimensions, finished rough opening dimensions and installation specifics.
- ▶ Allow the doors to open a minimum of 90° or you'll have problems removing drawers. With the doors opening at 90°, you may have to move drawers slightly to clear the door interior. Refer to the minimum door swing clearances in the specifications chart.
- ▶ For corner installations, allow for a minimum 3" (76) filler so that the door can open to 90°. If you're using raised panels, consider using a wider filler. A 90° door stop is available as an accessory.
- ▶ Be sure to add the filler strip width to your finished rough opening dimension. In any side-by-side installation without a filler strip, add an additional 1/2" (13) to your combined numbers. This will allow for the proper width.
- ▶ Refer to the full-scale illustrations at the end of this section for specifics on door openings and filler size alternatives.
- ▶ If your client has chosen the stainless steel design, the unit will be shipped complete with wrapped stainless steel doors and handle hardware. You will not have to install front panels.
- ▶ If your client has chosen the framed or overlay design, you will be adding front panels to give the unit the custom Sub-Zero look. The overlay design also allows you to add your own handles, or you may choose accessory handles available through your Sub-Zero dealer. Refer to pages 6–12 for detailed information on adding panels.
- ▶ For Built-In models with an automatic ice maker, rough in the water supply line. Connect a 1/4" OD copper line to the house supply, being sure to use an easily accessible shut off valve between the supply and the unit.
- ▶ Do not use self-piercing valves. A saddle valve kit (4200880) is available from your Sub-Zero dealer. To obtain local dealer information, visit the Locator section of our website, subzero.com.
- ▶ A line filter is required when water conditions have a high sediment content. The ice maker operates on water pressure of 20 psi (1.4 bar) to 100 psi (6.9 bar). In some cases a reverse osmosis water filter system may not be able to maintain the minimum water pressure consistently.
- ▶ The water line should be routed up through the floor within 1/2" (13) from the back wall and no higher than 3" (76) off the floor. If you have to come through the wall, make sure the water line is no more than 3" (76) from the floor. Locate water supply within the shaded area shown in the installation illustration.
- ▶ Regardless of the routing, allow 3' (.9 m) of excess copper tubing to remain outside the wall or floor for easy connection to the unit.
- ▶ A 115 volt, 60 Hz, 15 amp electrical supply is required. The supply circuit for this appliance must be protected by a 15 amp fuse or circuit breaker. It is recommended that a separate circuit, serving only this appliance, be provided.
- ▶ All Built-In models are equipped with a 6' (1.8 m) power supply cord with a 3-prong grounding plug which must be plugged into a mating 3-prong grounding type wall receptacle. Locate electrical within the shaded area shown in the installation illustration.
- ▶ You must follow all National Electrical Code regulations. In addition, be aware of local codes and ordinances when installing your service.
- ▶ To prevent the unit from tipping forward and provide a stable installation, the unit must be secured in place with an anti-tip blocking kit. If there is a solid soffit above the unit with clearance between the unit and the soffit of 1" (25) or less, you won't need to block the unit.
- ▶ For installations with clearances of more than 1" (25), you must block the unit with the anti-tip blocking kit (wood block and hardware) provided with each Built-In unit.
- ▶ Refer to the Built-In Installation Instructions packed with the appliance, which provides step-by-step procedures for making sure the unit is installed properly.

Built-In Model 685



BUILT-IN

FRAMED PANELS ▼

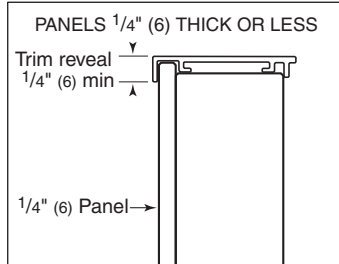

► Framed door panel 1/4" (6) thick or less

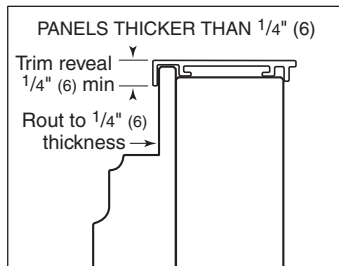

► Framed door panel thicker than 1/4" (6)

ADDING PANELS

In your plan for panels, be sure you are working with the Sub-Zero panel design family called for in your design. If you have chosen the stainless steel design, the unit will be shipped complete with wrapped stainless steel doors and handle hardware. You will not have to install front door panels.

If you and your client have ordered a framed or overlay design model, you will be adding panels to give the unit the custom Sub-Zero look. Specifications on the following pages provide installation considerations for framed and overlay door panels.

Side panels can be used with the framed, overlay and stainless steel design applications. Refer to specifications on page 12.

FRAMED PANELS

If the thickness of the custom panels is less than 1/4" (6), they must be backed up with a sheet of shim material to build the total thickness to 1/4" (6). If the panel is thicker than 1/4" (6), an edge must be routed around the panel to ensure a proper fit. Refer to the illustrations on this page.

IMPORTANT NOTE: Routing, recessing or optional extended handles may be required on raised panels for finger clearance under the handle. Refer to the full-scale illustrations on pages 13–16.

IMPORTANT NOTE: The weight of each panel cannot exceed 50 lbs (23 kg).

The traditional framed models come with an 11" (279) louvered grille and elegant full-length handle. Optional extended full-length handles that provide additional finger clearance for raised panels are available through your Sub-Zero dealer. To obtain local dealer information, visit the Locator section of our website, subzero.com.

For framed door panel dimensions and dimensions for the optional panel grille for the framed application, refer to specifications on page 7.

To install framed panels, refer to the installation instructions shipped with each unit. These instructions can also be found on our website, subzero.com.

Built-In Model 685



BUILT-IN

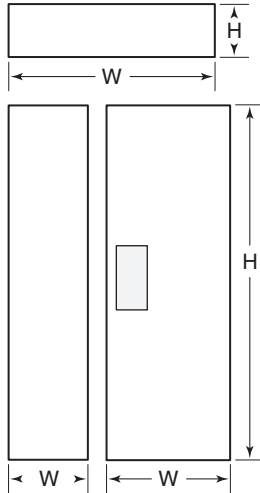

- ▶ Framed Door Panels
- ▶ Framed Grille Panel

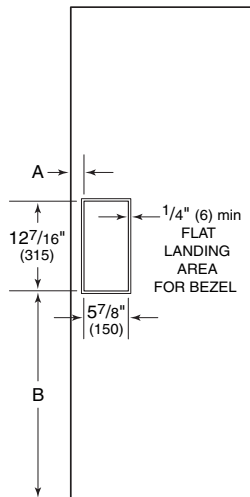

- ▶ Glasswell Cut-Out Location (refrigerator door panel)

▶ **IMPORTANT NOTE:** Panel thickness in the glasswell area can range from 1/4" (6) to a maximum of 1 1/8" (29). If the panel is thicker, you must rout out a minimum 1/4" (6) flat landing area to accommodate the bezel surrounding the glasswell.

FRAMED PANELS

For framed models, the refrigerator door panel must include a cut-out to accommodate the glasswell and bezel. The thickness of the panel in this area can range from 1/4" (6) to a maximum of 1 1/8" (29). If the panel is thicker, provisions must be made to rout out a space to accommodate the decorative bezel surrounding the glasswell.

An 11" (279) louvered grille is standard on framed applications. Optional louvered grilles are available in 1" (25) height increments from 10" (254) to 15" (381).

You may choose to use Sub-Zero's optional panel grille for the framed application. Optional panel grilles are available in 1" (25) height increments from 10" (254) to 15" (381). Refer to the chart below for panel dimensions.

FRAMED PANEL DIMENSIONS

	WIDTH	HEIGHT
Refrigerator Door Panel	24" (610)	67 ¹¹ / ₁₆ " (1719)
Freezer Door Panel	15 ⁵ / ₈ " (397)	67 ¹¹ / ₁₆ " (1719)
Maximum Weight (per panel)		50 lbs (23 kg)
Glasswell Cut-Out Location (refrigerator door panel)		A – 1 ⁹ / ₁₆ " (39) B – 28 ⁹ / ₁₆ " (726)

FRAMED GRILLE PANEL DIMENSIONS

	WIDTH	HEIGHT
10" (254) Grille	40 ³ / ₁₆ " (1021)	8 ¹⁵ / ₁₆ " (227)
11" (279) Grille	40 ³ / ₁₆ " (1021)	9 ¹⁵ / ₁₆ " (252)
12" (305) Grille	40 ³ / ₁₆ " (1021)	10 ¹⁵ / ₁₆ " (278)
13" (330) Grille	40 ³ / ₁₆ " (1021)	11 ¹⁵ / ₁₆ " (303)
14" (356) Grille	40 ³ / ₁₆ " (1021)	12 ¹⁵ / ₁₆ " (329)
15" (381) Grille	40 ³ / ₁₆ " (1021)	13 ¹⁵ / ₁₆ " (354)

Built-In Model 685



BUILT-IN

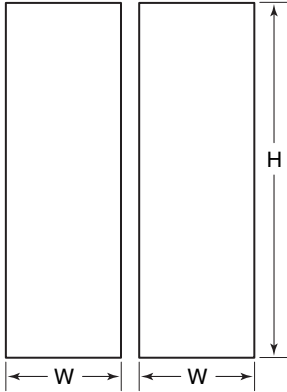

► *Partial Framed Door Panels (identical in size)*



► *Partial framed kit*

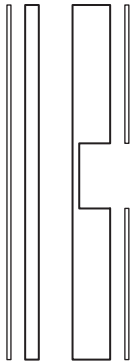

► *Framed retrofit kit*

FRAMED PANEL ACCESSORY KITS

For framed models, the refrigerator door panel must include a cut-out to accommodate the glasswell and bezel. The thickness of the panel in this area can range from 1/4" (6) to a maximum of 1 1/8" (29). If the panel is thicker, provisions must be made to rout out a space to accommodate the decorative bezel surrounding the glasswell.

If you choose not to use custom wood panels above or below the glasswell for the framed application, a stainless steel insert panel will be provided with the partial framed accessory kit. This accessory kit includes partial framed molding and classic stainless steel inset handle panel to provide a spill-resistant finish above and below the glasswell on the refrigerator door only. Refer to the specifications for this option in the chart below. Grille panel dimensions will be the same as shown for framed panels.

With the framed retrofit accessory kit, existing Model 680 door panels can be used on a new Model 685 framed unit. This accessory kit includes framed retrofit moldings and classic stainless steel inset handle panels to accommodate existing Model 680 framed refrigerator and freezer door panels.

IMPORTANT NOTE: When using a partial framed or framed retrofit kit, a 1/2" (13) reveal must be maintained on the bezel side of the panel.

Both accessory kits are available through your Sub-Zero dealer. To obtain local dealer information, visit the Locator section of our website, subzero.com.

PARTIAL FRAMED PANEL DIMENSIONS ▼

	WIDTH	HEIGHT
Refrigerator Door Panel	15 ⁵ / ₈ " (397)	67 ¹¹ / ₁₆ " (1719)
Freezer Door Panel	15 ⁵ / ₈ " (397)	67 ¹¹ / ₁₆ " (1719)

Built-In Model 685



BUILT-IN

OVERLAY PANELS ▼

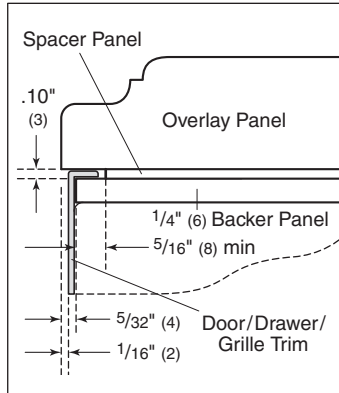

► Three panel assembly—cross section

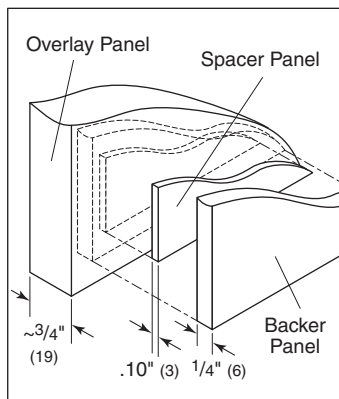

► Three panel assembly—rear view

OVERLAY PANELS

The overlay design allows decorative panels to cover the door trim for a more seamless appearance that blends with the design of the room. To achieve this look, the most common way is to work with three panels—the decorative overlay panel, a .10" (3) spacer panel and a 1/4" (6) backer panel. Depending on your cabinet manufacturer, this could be one panel routed for different dimensions or more likely, three different panels.

Regardless of the physical construction of the panels (routing or three panel assembly), you will need to follow the exact dimensions and panel placement to ensure a proper fit.

The top illustration on this page is a cross section view of the three panel assembly showing placement of the door/drawer/grille trim. The bottom illustration shows a rear view of the three panel assembly and critical dimensions, standard for all overlay models.

Overlay models will come with no handle hardware, because the beauty of this design is that you can match the surrounding cabinetry hardware. These models will come with an 11" (279) panel grille which will accept decorative panel inserts to match the look of the door panels. For overlay door and grille panel dimensions, refer to specifications on page 10.

IMPORTANT NOTE: Keep in mind that the Sub-Zero door panels have the potential for hitting adjacent cabinets and/or countertops when they are opened. You need to be aware of your surrounding cabinetry and space limitations when using the overlay models. Refer to the full-scale illustrations on pages 15–16.

IMPORTANT NOTE: The weight of each door panel assembly cannot exceed 50 lbs (23 kg). The total thickness of all panels for an overlay model must be at least 5/8" (16) thick.

To install overlay panels, refer to the installation instructions shipped with each unit. These instructions can also be found on our website, subzero.com.

⚠ CAUTION

Do not exceed the dimensions listed for the overlay grille panel. The decorative panel cannot be any larger or it may restrict the air flow to the compressor area and cause problems with the operation of the unit.

Built-In Model 685



BUILT-IN

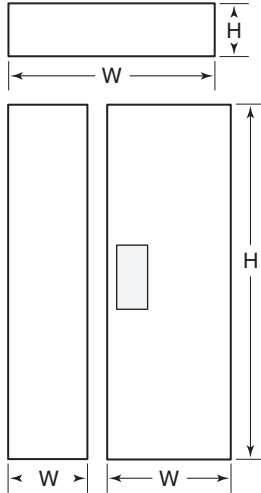

- ▶ Overlay Door Panels
- ▶ Overlay Grille Panel

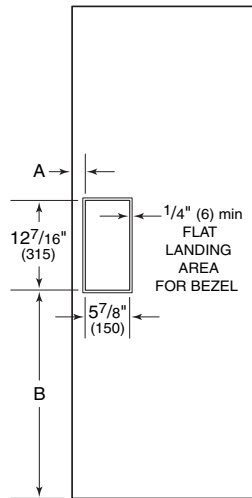

- ▶ Glasswell Cut-Out Location (refrigerator door panel)

▶ **IMPORTANT NOTE:** Panel thickness in the glasswell area can range from $\frac{1}{4}$ " (6) to a maximum of $\frac{1}{8}$ " (29). If the panel is thicker, you must rout out a minimum $\frac{1}{4}$ " (6) flat landing area to accommodate the bezel surrounding the glasswell.

OVERLAY PANELS

An 11" (279) panel grille is standard on overlay applications. Optional panel grilles are available in 1" (25) height increments from 10" (254) to 15" (381).

OVERLAY PANEL DIMENSIONS

	WIDTH	HEIGHT
Refrigerator Door Panel	24 ⁵ / ₁₆ " (618)	68" (1727)
Refrigerator Door Spacer	23 ³ / ₈ " (594)	67 ¹ / ₁₆ " (1703)
Refrigerator Door Backer	24" (610)	67 ¹¹ / ₁₆ " (1719)
Freezer Door Panel	15 ¹⁵ / ₁₆ " (405)	68" (1727)
Freezer Door Spacer	15" (381)	67 ¹ / ₁₆ " (1703)
Freezer Door Backer	15 ⁵ / ₈ " (397)	67 ¹¹ / ₁₆ " (1719)
Maximum Weight (per panel assembly)	50 lbs (23 kg)	
Glasswell Cut-Out Location (refrigerator door panel)	A – 1 ¹¹ / ₁₆ " (43) B – 28 ³ / ₄ " (730)	
Glasswell Cut-Out Location (refrigerator door spacer)	A – 1 ¹ / ₄ " (31) B – 28 ¹ / ₄ " (718)	
Glasswell Cut-Out Location (refrigerator door backer)	A – 1 ⁹ / ₁₆ " (39) B – 28 ⁹ / ₁₆ " (726)	

OVERLAY GRILLE PANEL DIMENSIONS

	WIDTH	HEIGHT
10" (254) Grille Panel	40 ⁷ / ₁₆ " (1027)	9 ¹ / ₄ " (235)
10" (254) Grille Spacer	39 ¹ / ₂ " (1003)	8 ⁵ / ₁₆ " (211)
10" (254) Grille Backer	40 ¹ / ₈ " (1019)	8 ¹⁵ / ₁₆ " (227)
11" (279) Grille Panel	40 ⁷ / ₁₆ " (1027)	10 ¹ / ₄ " (260)
11" (279) Grille Spacer	39 ¹ / ₂ " (1003)	9 ⁵ / ₁₆ " (237)
11" (279) Grille Backer	40 ¹ / ₈ " (1019)	9 ¹⁵ / ₁₆ " (252)
12" (305) Grille Panel	40 ⁷ / ₁₆ " (1027)	11 ¹ / ₄ " (286)
12" (305) Grille Spacer	39 ¹ / ₂ " (1003)	10 ⁵ / ₁₆ " (262)
12" (305) Grille Backer	40 ¹ / ₈ " (1019)	10 ¹⁵ / ₁₆ " (278)
13" (330) Grille Panel	40 ⁷ / ₁₆ " (1027)	12 ¹ / ₄ " (311)
13" (330) Grille Spacer	39 ¹ / ₂ " (1003)	11 ⁵ / ₁₆ " (287)
13" (330) Grille Backer	40 ¹ / ₈ " (1019)	11 ¹⁵ / ₁₆ " (303)
14" (356) Grille Panel	40 ⁷ / ₁₆ " (1027)	13 ¹ / ₄ " (337)
14" (356) Grille Spacer	39 ¹ / ₂ " (1003)	12 ⁵ / ₁₆ " (313)
14" (356) Grille Backer	40 ¹ / ₈ " (1019)	12 ¹⁵ / ₁₆ " (329)
15" (381) Grille Panel	40 ⁷ / ₁₆ " (1027)	14 ¹ / ₄ " (362)
15" (381) Grille Spacer	39 ¹ / ₂ " (1003)	13 ⁵ / ₁₆ " (338)
15" (381) Grille Backer	40 ¹ / ₈ " (1019)	13 ¹⁵ / ₁₆ " (354)

Built-In Model 685



BUILT-IN

OVERLAY PANELS ▼

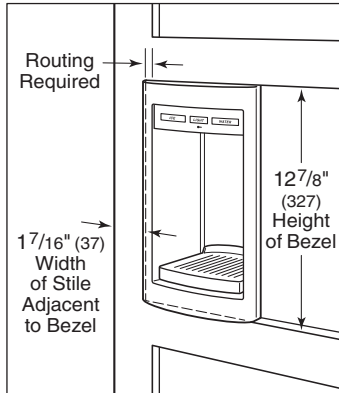

► Glasswell cut-out option

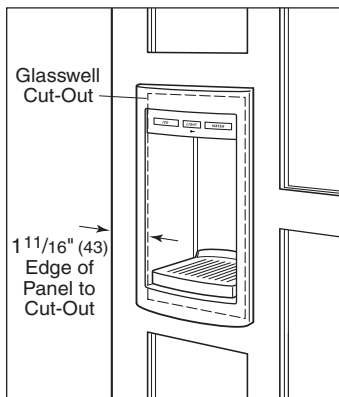

► Glasswell cut-out option

OVERLAY PANELS

For overlay models, the refrigerator door panel must include a cut-out to accommodate the glasswell and bezel. The thickness of the panel in this area can range from $\frac{1}{4}$ " (6) to a maximum of $1\frac{1}{8}$ " (29).

IMPORTANT NOTE: Regardless of the thickness of the overlay panel for Model 685, you must plan for a flat "landing" space for the decorative bezel surrounding the glasswell area. Refer to page 10 for exact cut-out dimensions of the glasswell area in the overlay, spacer and backer panels. This "landing" area can be accomplished in a number of different ways. We are showing two options in the illustrations on this page.

The top illustration shows how you can recess the bezel to the inset panel. You must rout out a space to accommodate the $12\frac{7}{8}$ " (327) height of the bezel. Also keep in mind that the amount of material you will rout out of the stile will vary because of the thickness of this element. However, the width of the stile immediately adjacent to the bezel must be $1\frac{7}{16}$ " (37). DO NOT cut the entire stile to this dimension. In this illustration you can see that rails above and below the bezel give this a finished look. Make sure that the bezel is not supporting weight from the panel.

The bottom illustration shows how you can box out a landing space for the bezel using stiles and rails to create this space. Again, keep in mind, that the total thickness of the panel at this level must not exceed $1\frac{1}{8}$ " (29).

Built-In Model 685



BUILT-IN

SIDE PANELS ▼

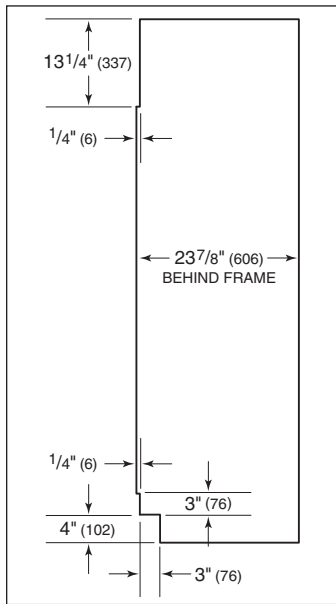

- *Cut-outs for grille and toe kick area*

HANDLE PROFILE ▼

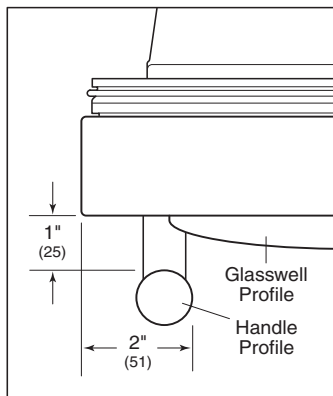

- *Handle and glasswell profile for stainless steel Model 685*

SIDE PANELS

Side panels can be used with the framed, overlay and stainless steel design applications. When planning for side panels with the installation of the Built-In model, you need to be aware of space configuration to achieve a pleasing fit. Depending on the exact panel you are using with your unit, the height of the panel will vary.

Cut-outs around the toe kick and grille area are required if a 1/4" (6) thick panel will be inserted into the main frame channel. The panel will need to be 24" (610) deep. Refer to the illustration on this page for placement of toe kick and grille area cut-outs. If a 3/8" (10) thick panel is used, the panel will abut the main frame and should be 23 7/8" (606) deep. The toe kick area may or may not be cut out depending on the look you want to achieve.

IMPORTANT NOTE: The use of side panels may change the width of your rough opening.

HARDWARE CONSIDERATIONS

Overlay models come without handle hardware. The beauty of this design is that you can match the surrounding cabinet hardware. You or the cabinet manufacturer must provide handle hardware to match the overall decorating scheme.

The handle hardware must be installed before installing the panel assembly. Use larger D-style handles. If screws with thick heads are used, the screws will need to be countersunk into the door before the panel is put into place. Refer to the full-scale illustrations on pages 13-14 for handle hardware considerations.

IMPORTANT NOTE: Sub-Zero does not recommend using single pull knobs on any of its Built-In models.

For overlay models, mounting placement of the refrigerator door handle must assure proper access to the glasswell and adequate clearance under the handle. The illustration at left shows placement of the refrigerator door handle in relationship to the glasswell bezel on stainless steel models.

Optional stainless steel handles are available in a variety of diameters and lengths in the classic, platinum and carbon stainless steel finishes and polished chrome. Contact your Sub-Zero dealer for specifics. To obtain local dealer information, visit the Locator section of our website, subzero.com.

Built-In Model 685

HANDLE PROFILE - FRAMED APPLICATION

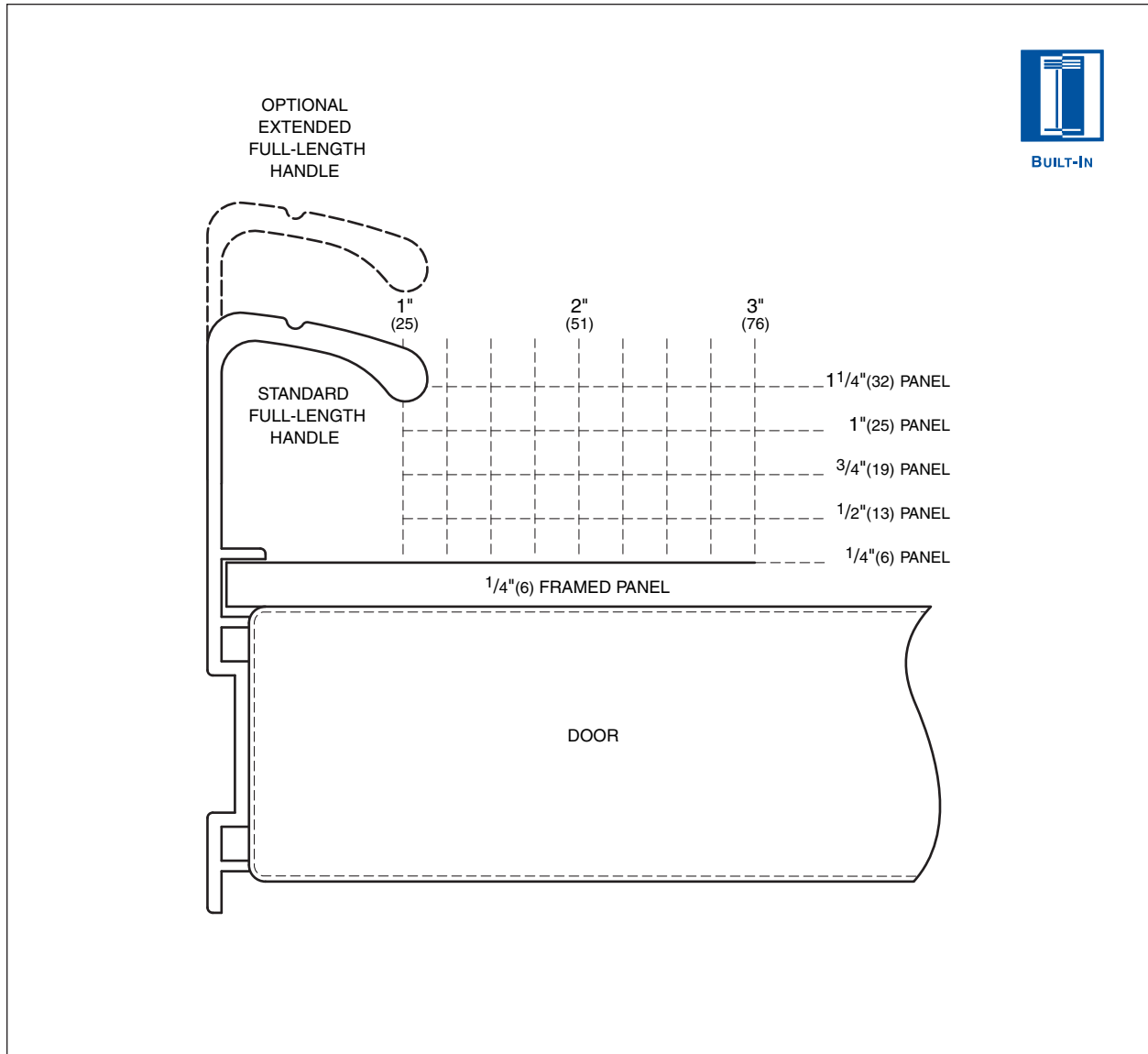

FULL-SCALE TEMPLATES

The following full-scale illustrations enable you to understand some of the unique situations you may face as you design the Built-In units into homes. These templates can be easily photocopied or used in your tracings.

HANDLE PROFILE

The full-scale illustration above shows handle placement for the framed application standard full-length handle and the optional extended full-length handle shown in the dashed line.

Built-In Model 685

HANDLE PLACEMENT - OVERLAY APPLICATION

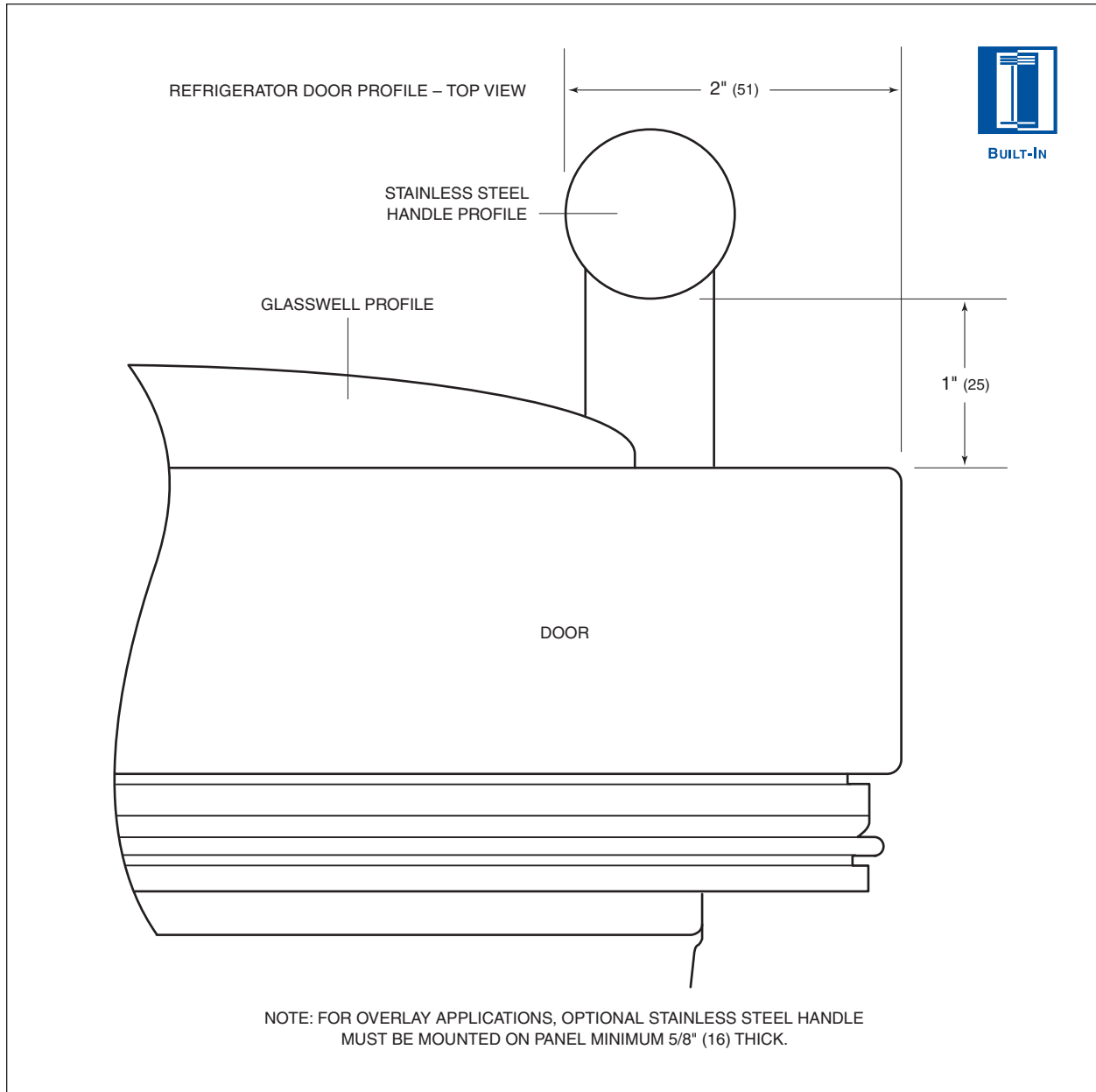

HANDLE PLACEMENT

The full-scale illustration above shows proper placement of the stainless steel handle for the Model 685 refrigerator door in an overlay application.

Adequate clearance is required under the handle to assure proper access to the glasswell.

IMPORTANT NOTE: For overlay applications, the optional stainless steel handle must be mounted on a panel at least $\frac{5}{8}$ " (16) thick.

Built-In Model 685

PANEL AND HANDLE PROFILE - 130° DOOR OPENING

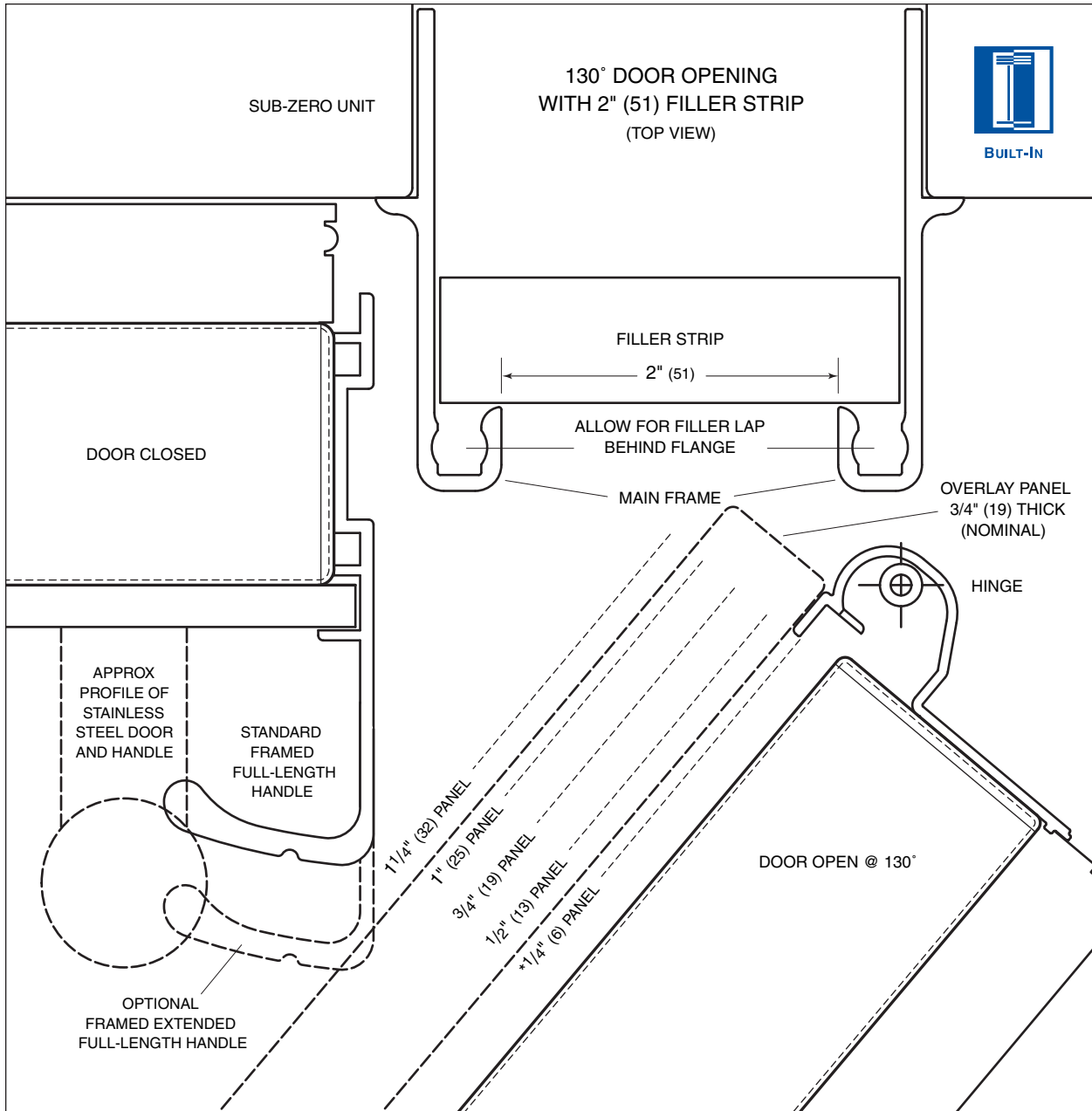

The full-scale illustration above shows the panel and handle profile of a 130° door opening with 2" (51) filler strip for framed applications.

Interference of door panels with handles at maximum door swing may require the use of an optional 90° door stop available through your Sub-Zero dealer.

**Approximate thickness of wrapped stainless steel door.*

Dimensions in parentheses are in millimeters unless otherwise specified.

To obtain local dealer information, visit the Locator section of our website, subzero.com.

The full-scale illustration on the following page lets you see what considerations you need to make for any overlay panel applications, and how they may interact with adjacent cabinets and/or countertops.

Built-In Model 685

OVERLAY PANEL APPLICATION - 90° DOOR OPENING

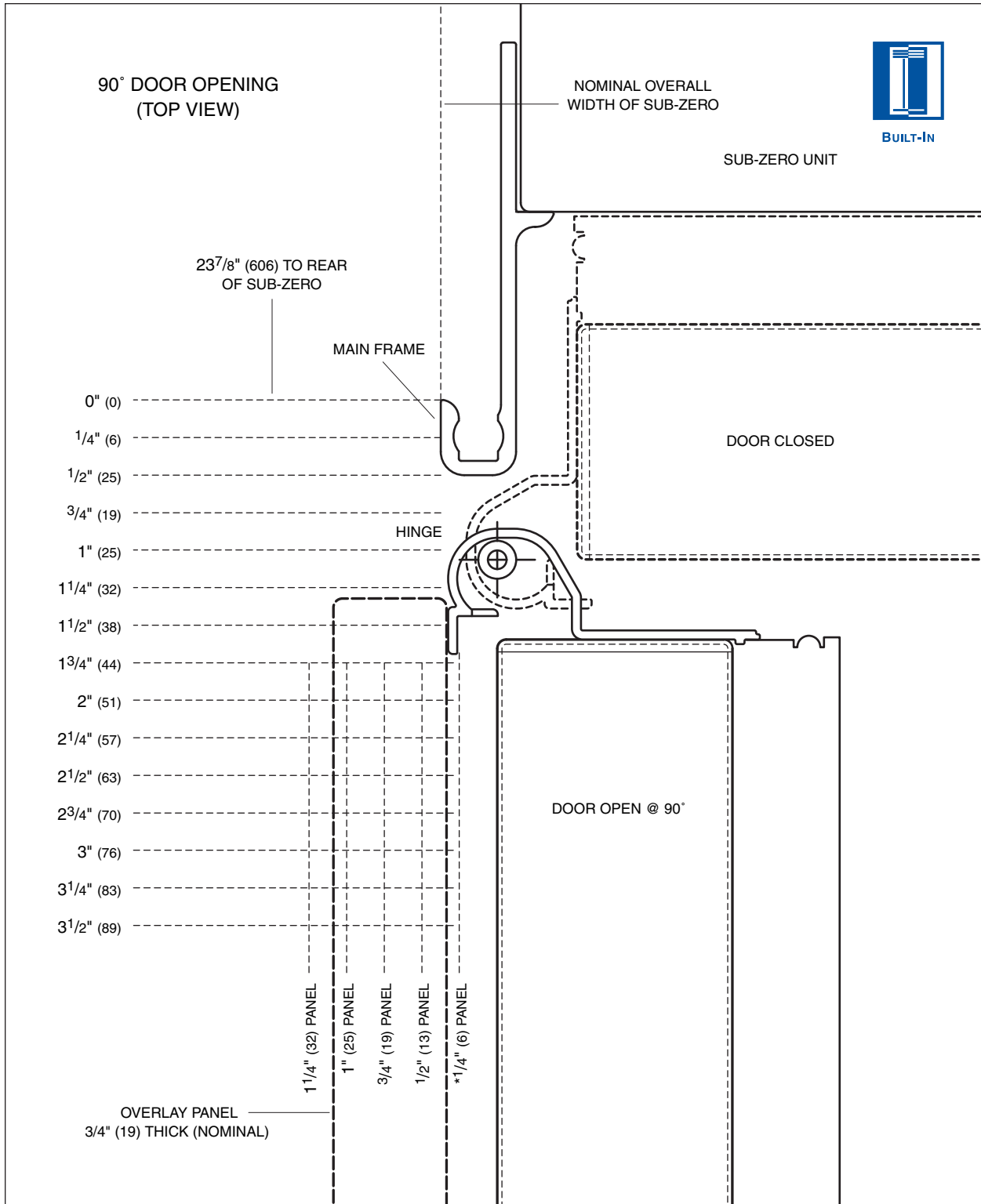

*Approximate thickness of wrapped stainless steel door.

Dimensions in parentheses are in millimeters unless otherwise specified.